

Product Installation Checklist

No.	Check and confirm before powering on	Reference	Checked <input checked="" type="checkbox"/>
1	Confirm that the fixing screws of the battery module and inverter are installed correctly.	Pages 6-8	<input type="checkbox"/>
2	Confirm that all module casing grounding screws of the energy storage system are reliably interconnected, and the entire system is connected from the inverter heat sink to the external grounding point.	Page 9	<input type="checkbox"/>
3	Confirm that the COM wiring harness terminals of the battery module are properly and reliably plugged in, and that the dip switch distinguishes between master and slave devices according to requirements;	Page 9	<input type="checkbox"/>
4	Confirm that the CAN connection between the inverter BMS/CAN port and the battery control unit is standardized and reliable;	Page 9	<input type="checkbox"/>
5	Confirm that the power harness terminals of the battery module are properly and reliably plugged in;	Pages 10-11	<input type="checkbox"/>
6	Confirm that the wire sequence (positive and negative) of the inverter PV port is correct, and that the terminal crimping and plugging are standardized and reliable.	Page 13	<input type="checkbox"/>
7	Confirm that the wire sequence (L N PE) on both sides of the inverter's GRID, EPS, and meter ports is correct, and that the terminal crimping and plugging are standardized and reliable.	Pages 12-13	<input type="checkbox"/>
8	Confirm that the inverter GRID and EPS port circuits are independent, with phase lines not interconnected and neutral lines not interconnected.	Page 1	<input type="checkbox"/>
9	Confirm that the GRID and EPS ports of the inverter are first connected to the residual current action protector before supplying power to the load;	Page 1	<input type="checkbox"/>
10	Confirm that the connection between the inverter MET port and the meter communication interfaces 21 (485A) and 22 (485B) is standardized and reliable;	Page 13	<input type="checkbox"/>
11	Confirm that the "PV SWITCH" switch of the inverter and all switches connected to the product are in the "OFF" state;	Pages 14-15	<input type="checkbox"/>

QUICK INSTALLATION GUIDE

All-in-One ESS

AE3.6/4/4.6/5K-L1-S & AES5.1-L Series

V1.3(20250725)



Read User
Manual First



Wear Appropriate
Personal Protection
Equipments



CAUTION



WARNING!
Electric shock

CAUTION! MAX PV Voltage: 500V

ELECTRICAL CONNECTION DIAGRAM

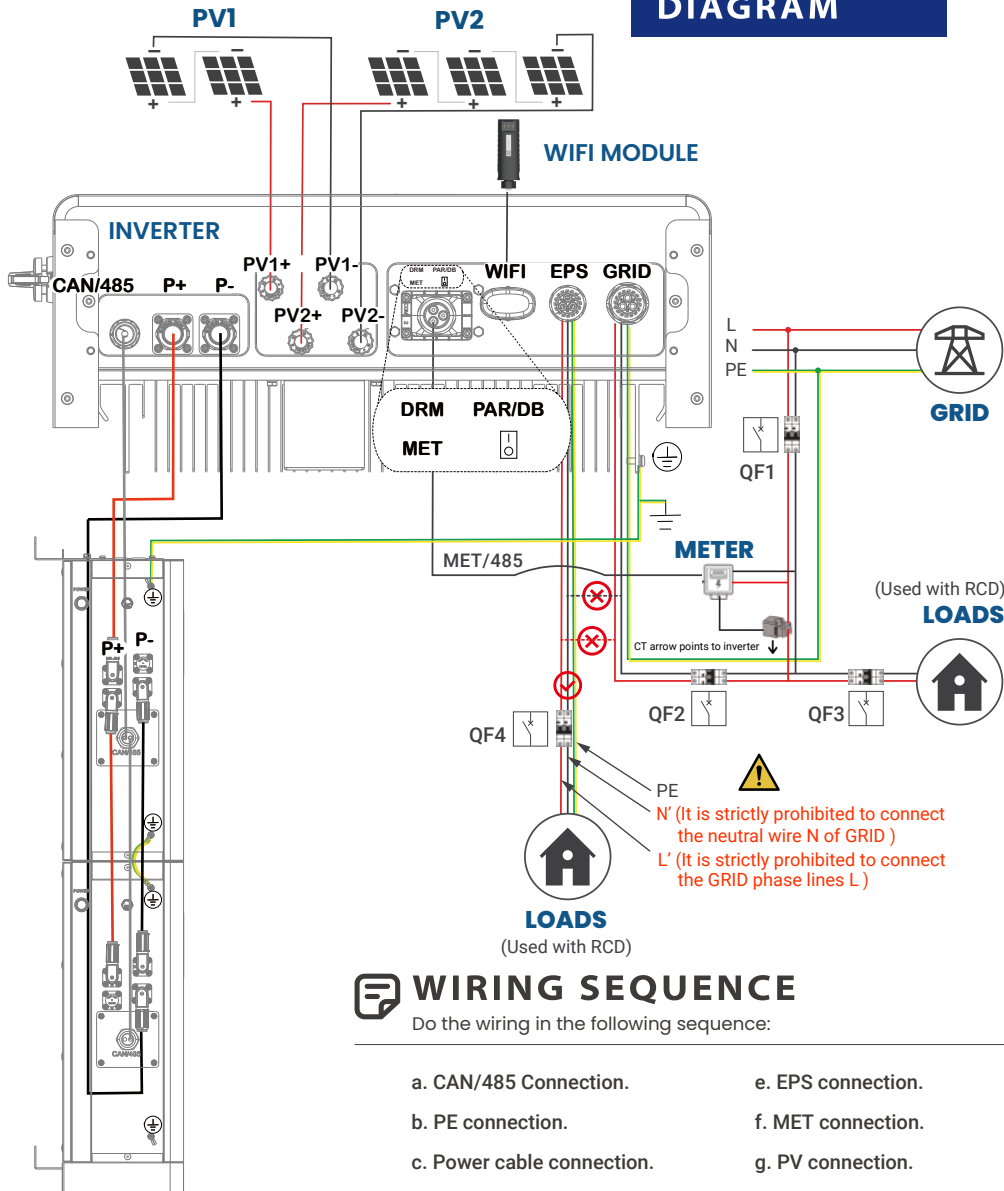

WIRING SEQUENCE

Do the wiring in the following sequence:

- | | |
|----------------------------|----------------------------|
| a. CAN/485 Connection. | e. EPS connection. |
| b. PE connection. | f. MET connection. |
| c. Power cable connection. | g. PV connection. |
| d. GRID connection. | h. WiFi module connection. |

Instructions for the sequence and wiring of battery packs with different capacity combinations

- P+/P- wiring port
- CAN/485 wiring port

- Positive power cable
- Negative power cable
- CAN/485 cable

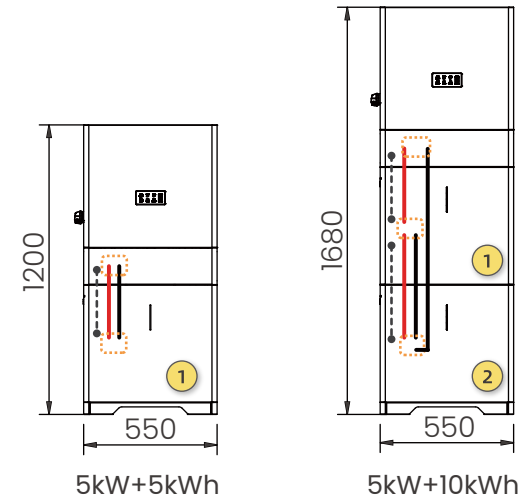

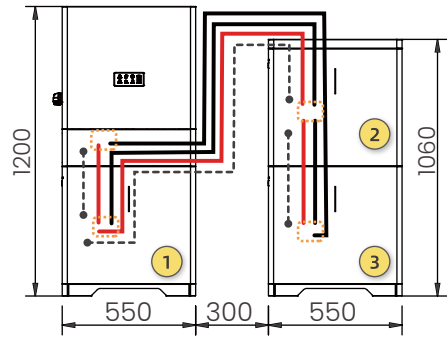

5kW+15kWh

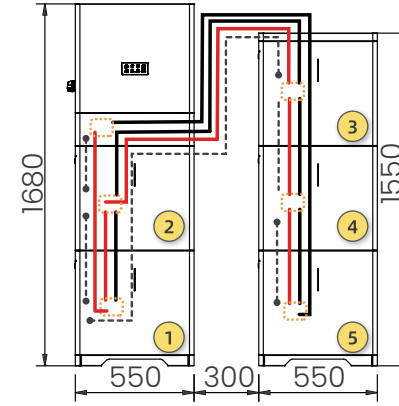

5kW+25kWh

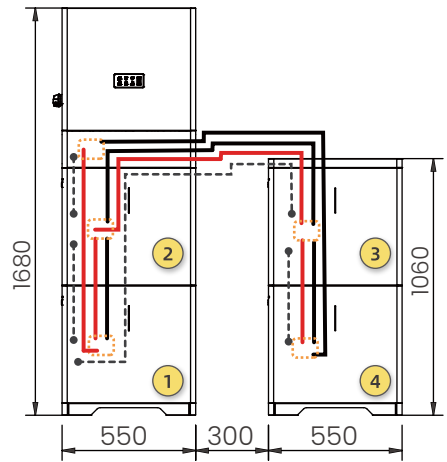

5kW+20kWh

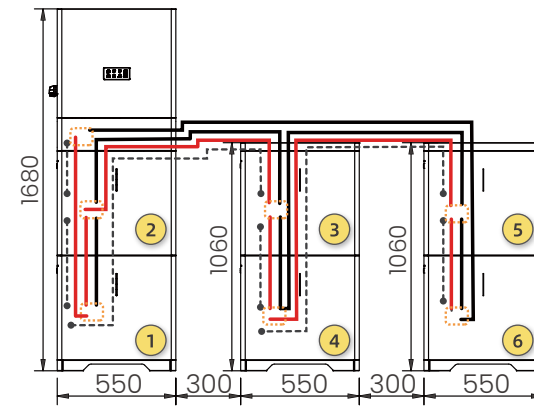

5kW+30kWh

1. Packing List

Please confirm the materials according to the packing list inside the packaging box.

2. Space Requirements

Reserve enough space around the Pack and inverter to ensure space for installation, maintenance, and heat dissipation.

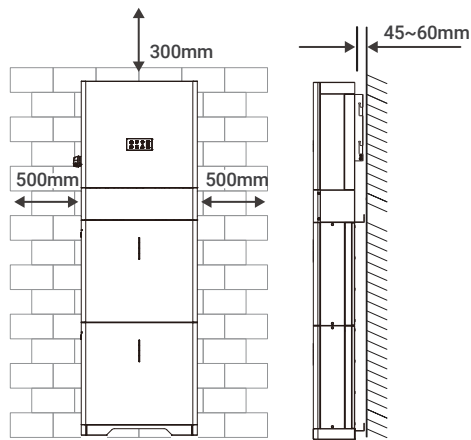

⚠ WARNING!

The battery will be damaged if it is dropped or hit strongly during installation. It is strictly prohibited to use it, there may be serious safety risks such as potential leakage of battery cells, click injury or fire etc.

3. Battery Pack Installation

3.1: Place the base in parallel to the wall on a flat surface, 45-60mm away from the wall, keep the base level and mark the position of hole.

The base supports two fixing methods: ground-fixed (option I) and wall-fixed (option II). User can choose one according to the actual situation.

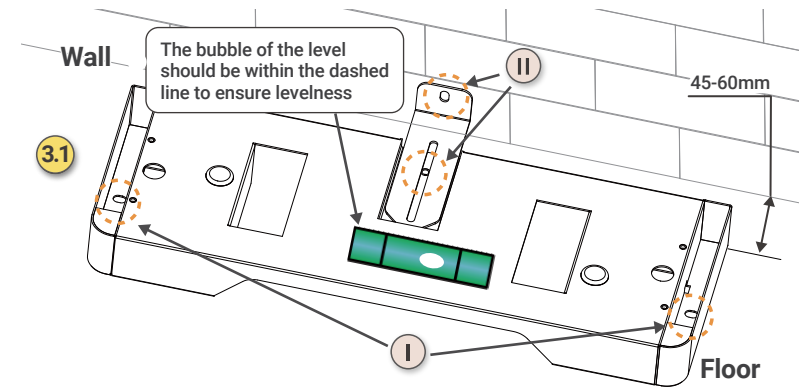

3.2: Drill holes with an impact drill ($\Phi 8\text{mm}$, Depth: 85-95mm).

For the ground-fixed method, it is fixed with two M6 expansion screws (option I), for the wall-fixed method, it is fixed with one M6 expansion screw and one M6 ordinary screw (option II).

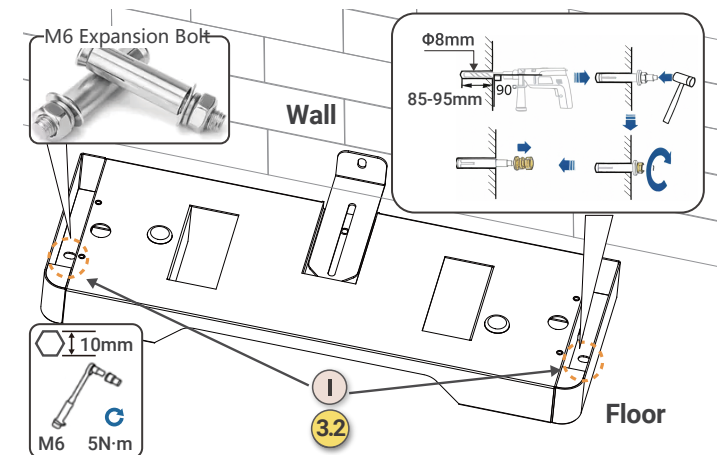

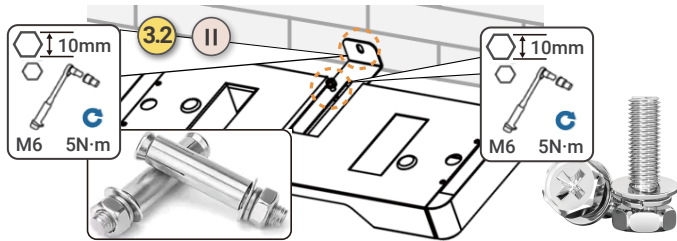

3.3: Place the battery pack (Qty. of packs in a single row: ≤ 3) and mount M5 screws at both sides (3N.m).

 When using electric tools to install screws, ensure vertical alignment, slow speed, and small torque to avoid stainless steel screws locking.

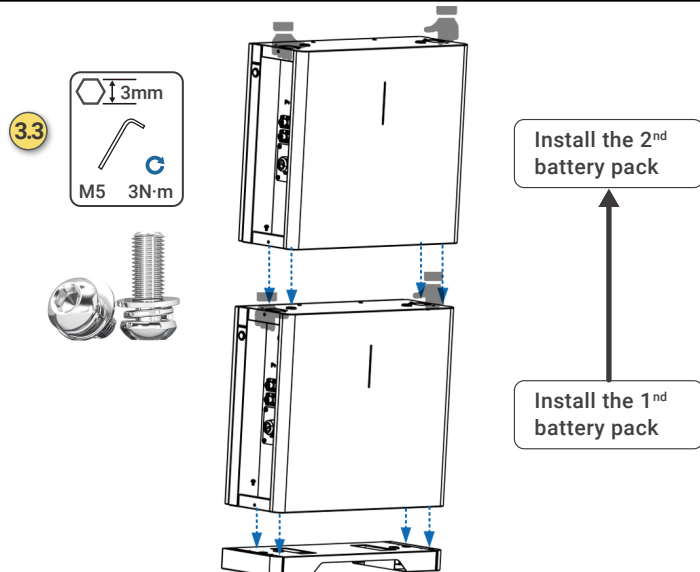

3.4: Put the wall-fixing bracket at the top of battery, mark the position of hole, dismantle the wall-fixing bracket and drill holes with an impact drill ($\Phi 8\text{mm}$, Depth: 85-95mm). Collect the scraps by cover plate during the drilling process.

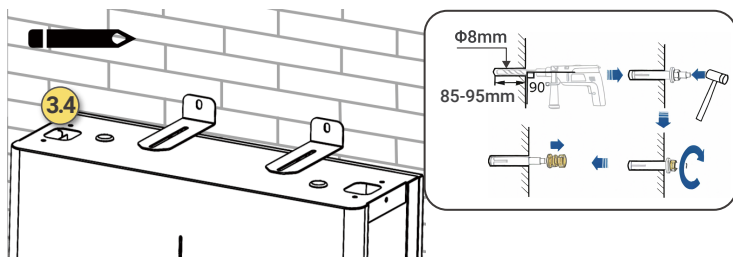

3.5: Install the wall-fixing bracket using M6 expansion bolt and general screw to fix the equipment.

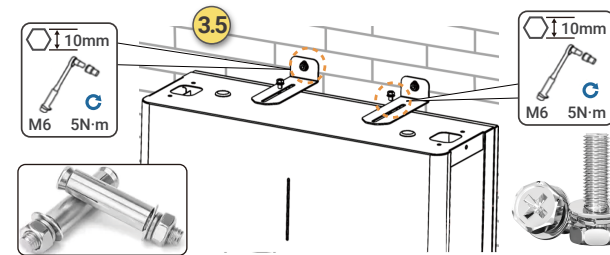

4. Inverter Installation

4.1: Place the inverter upside down inside the packaging box and install the leg. Remove the waterproof cover with short handled cross-head screwdriver.

Note: The support leg marked 1 at the top is installed near the PV switch side.

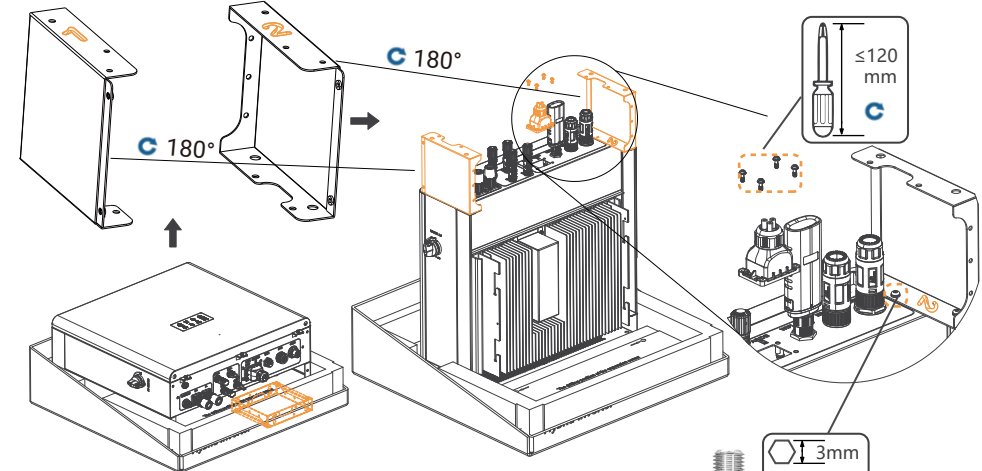

4.2: Fix the inverter on the battery.

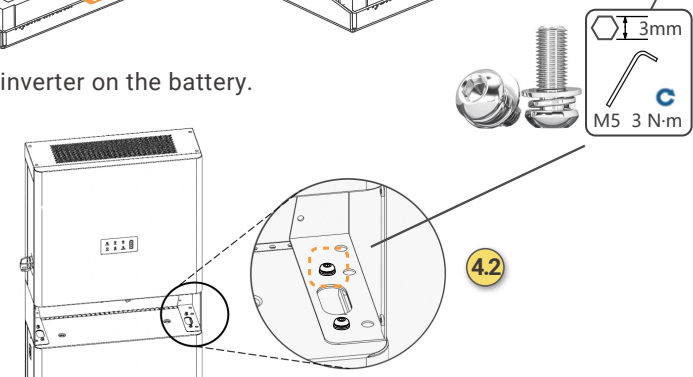

5. BESS wiring sequence

! It is forbidden to close the circuit breaker manually for battery pack before wiring is complete!

📄 Prepare the wires before wiring.

a. CAN/485 Connection

a1: Open the CAN/485 waterproof cover.

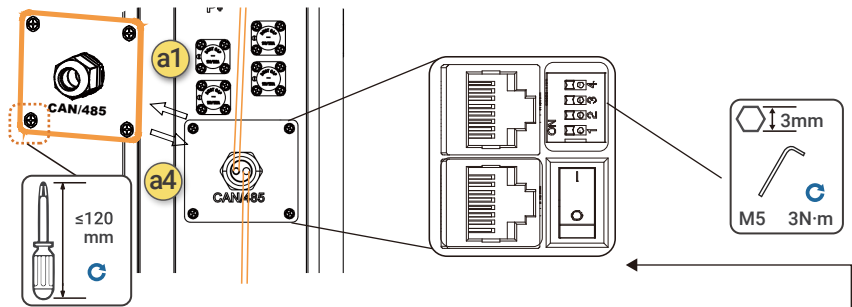

a2: Pass the CAN/485 cable through the waterproof cover of the battery pack and connect it to the CAN/485 interface of the battery pack. Connect the other end to the CAN/485 interface of other battery packs. Connect all battery packs repeatedly.

a3: Connect the CAN/485 harness from the first battery pack to the inverter.

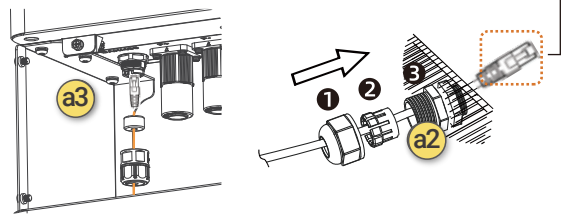

a4: Intall the waterproof cover.

b) PE connection

📄 Refer to user manual for wire preparation. (Single Phase Hybrid Inverter) Page 23

b1: Make the system PE wire for external connection using the terminal block accompanied with the packaging box.



b2: Connect different battery packs using the PE harness provided with the battery pack (b2 harness in next page). Multiple rows of battery packs are connected with extended PE harnesses, as indicated by the dashed line in the next page.

b3: Connect the PCS to the nearest battery pack using the PE harness provided with the PCS (b3 harness in next page), and ground it separately with a self-made system external PE wire (b1 harness in next page).

c. Power cable connection

c1: Connect the battery packs with the power harness (c1 harness in next page) provided with the battery pack in parallel in order, 1-2-3-4-5, connect P+ to P+ and P- to P-.

Note: The sequence and wiring instructions for battery packs with different capacity combinations are shown in the diagram on the front of the brochure.

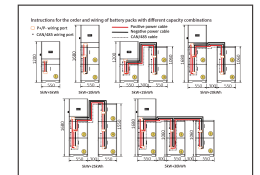

The next page shows the wiring instructions for 10kWh battery packs.

(see page 02-04)

c2: First, connect the P+ power harness between the inverter and the first battery pack (No. 1), and then connect the P- power harness between the inverter and the last battery pack (No. 2) (c2 harness in next page).

The connection method of waterproof terminal is as follows:

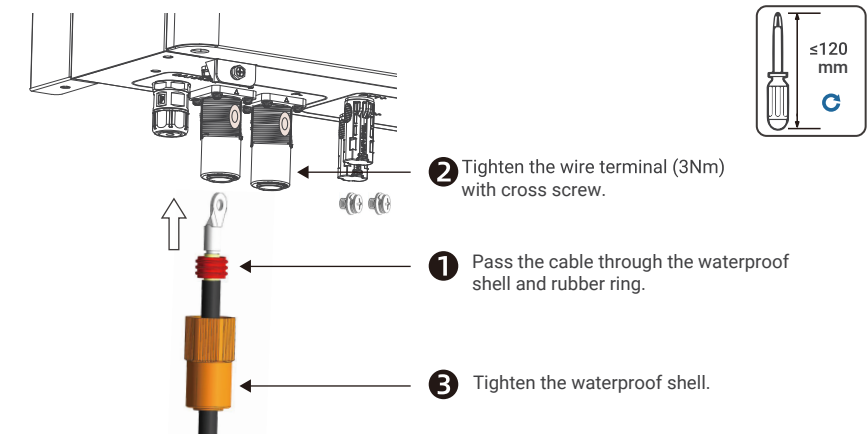

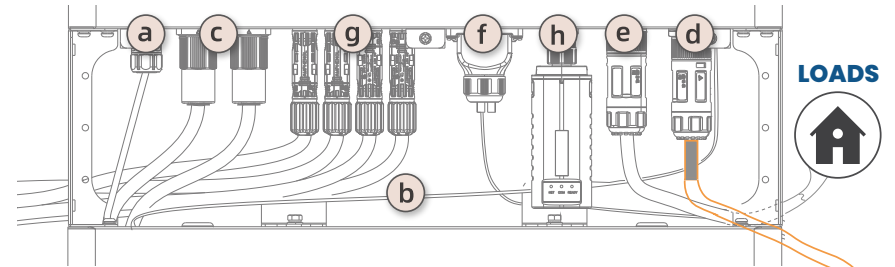
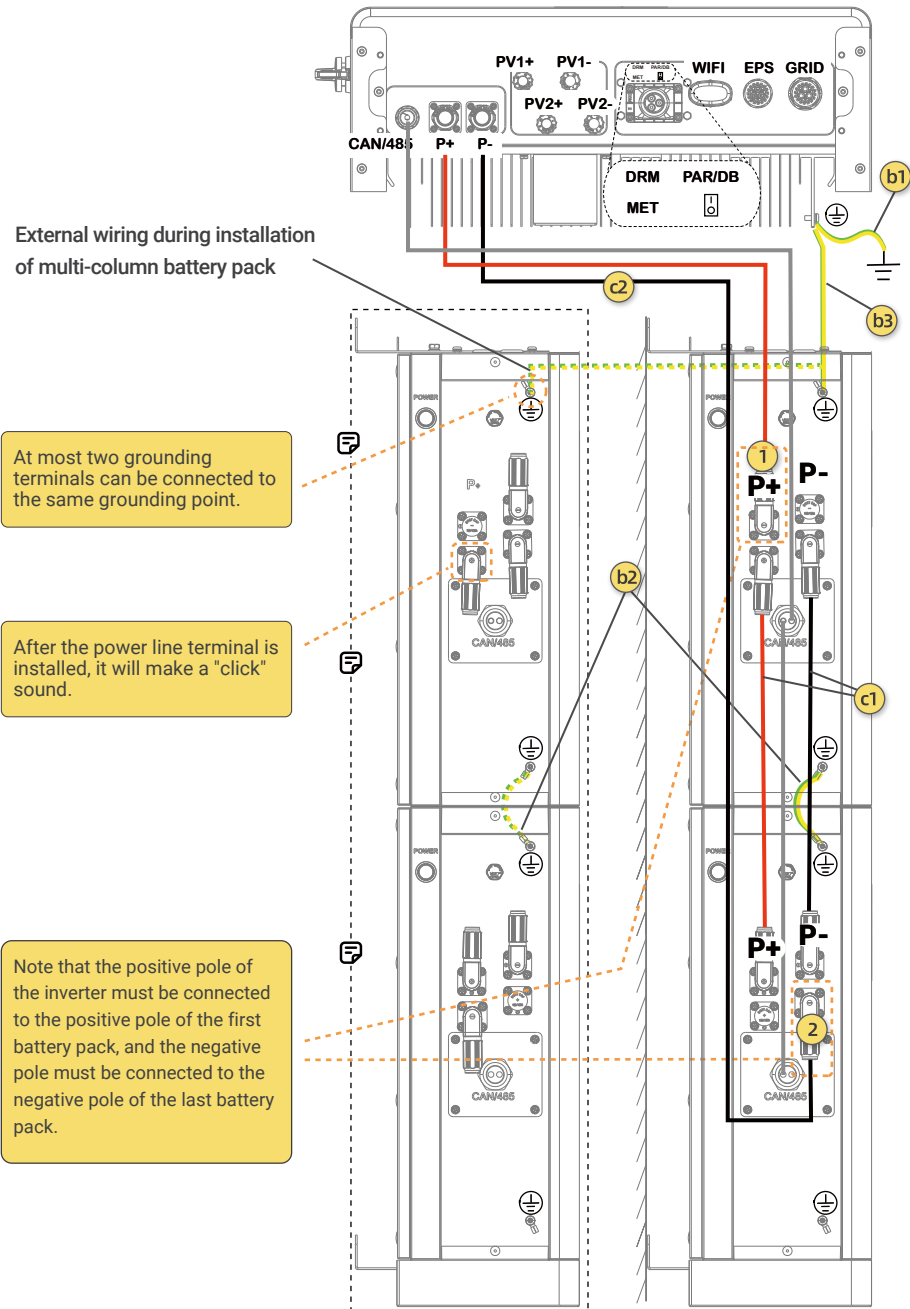

d) GRID connection.

Refer to user manual for wire preparation. (Single Phase Hybrid Inverter) Page 23



CAUTION!

It is strictly prohibited to connect the neutral wires of EPS and GRID, otherwise it may cause leakage current to exceed the limit.



CAUTION!

It is strictly prohibited to connect the phase lines of EPS and GRID, otherwise it may cause equipment damage.

d1: Make GRID connection harness.

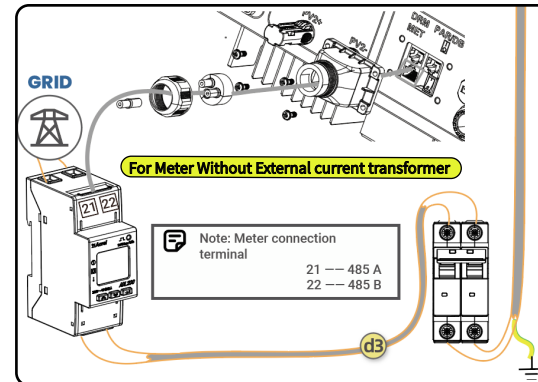
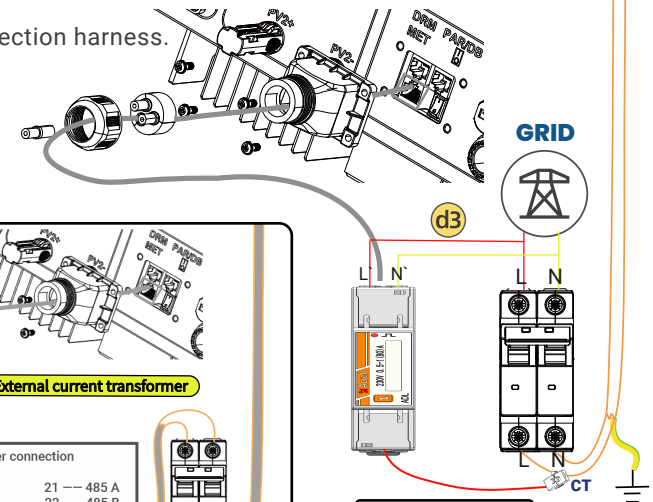

d2: Plug-in the GRID connection harness into the corresponding GRID interface on the inverter.

d3: Install meter and circuit breaker on GRID.

CAUTION!
CT arrow points to inverter

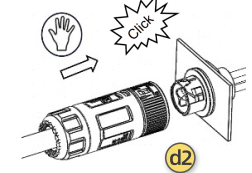

e) EPS connection

Refer to user manual for wire preparation.

(Single Phase Hybrid Inverter) Page 23

e1: Make EPS connection harness.

e2: Plug-in the EPS connection harness into the corresponding EPS interface on the inverter.

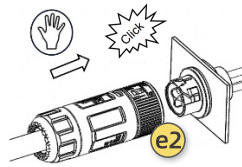

f) MET connection

f1: Run the communication harness through the waterproof shell to install it on MET interface of PCS.

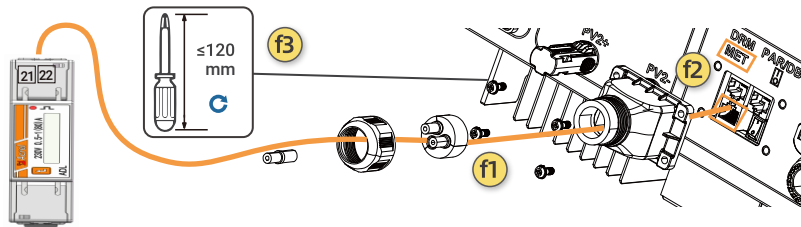

f2: Plug-in the meter communication harness to 21/22 communication interface of meter.

f3: Install the waterproof cover with short handled cross-head screwdriver.

g) PV connection.

Refer to user manual for wire preparation.

(Single Phase Hybrid Inverter) Page 25

CAUTION! Check PV voltage (150-500V) and avoid reverse connection. Cut off PV DC switch before installation.

g1: Make PV connection harness.



g2: Plug-in the PV connection harness into PV interface on the inverter (PV1+/PV1-/PV2+/PV2-).

h) WiFi module connection

h1: Install WiFi module to WiFi interface of PCS.

6. Device powering on & APP setting

6.1 Device powering on

The last page is accompanied by a checklist. After checking for accuracy, turn on the power according to the recommended sequence.

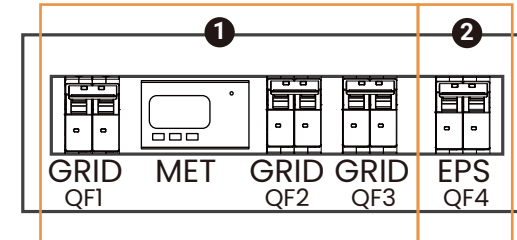

(Distribution box: Diagram QF1-4 corresponds to the electrical connection diagram on page 1)

Step 1: Switch -ON the GRID air circuit breakers (1) in the distribution box;

Step 2: Switch -ON the EPS air circuit breaker (2) in the distribution box.

Step 3: Switch -ON the PV switch (3) of the inverter;

Step 4: Press and hold 'POWER' button (4) on all battery packs > 3s.

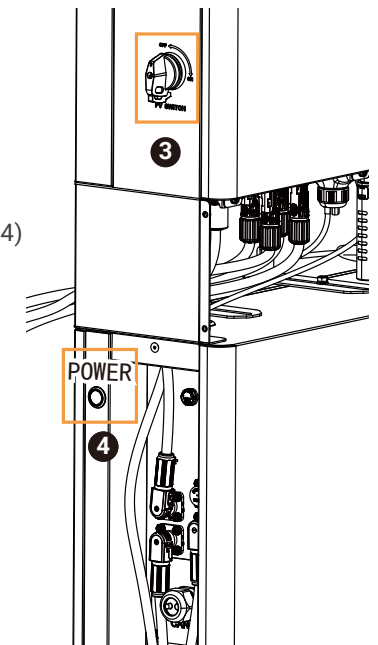

Note: After DC power is applied, the system LED has a waiting period of approximately 90 seconds.

6.2 Home Setting

Step 1: Download 'SOLARMAN Smart' EMS APP from Google Play/Apple App Store.

Step 2: Sign up and login your account in "SOLARMAN Smart" EMS APP.

Step 3: Click "Start" to create your plant on SOLARMAN Smart.

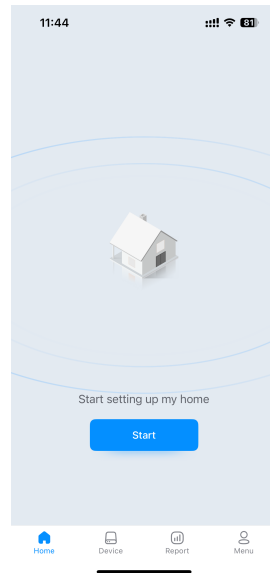

Step 4: Enter Home Details.

Please enter the address to search for the location of the power station, and click "Add" after confirmation.

Follow the prompts to improve the power supply, photovoltaic and battery conditions of the power station, etc., the more complete the power station information is filled, the more conducive to your power station management.

After completing the power station information, you can click the "Done" button, and the page will appear in a successful window.

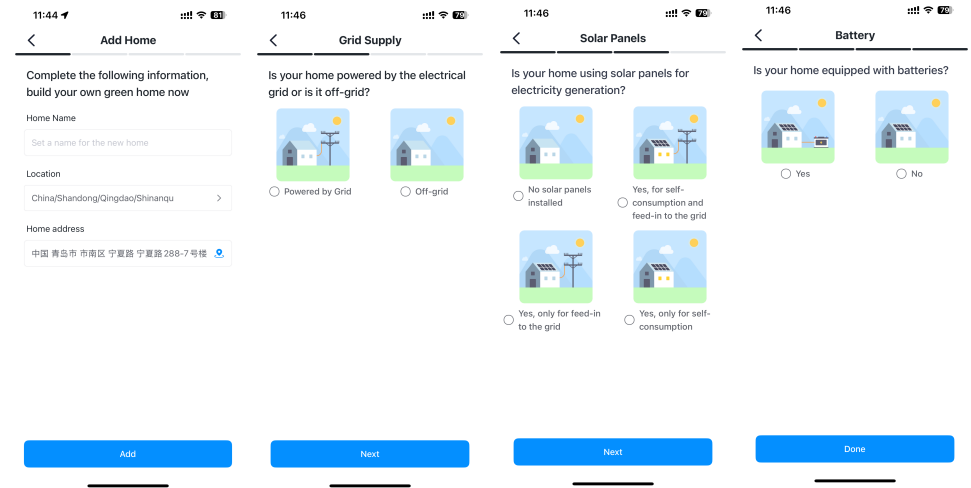

6.3 WIFI Module Setting

Step 1:

Click the "Start" button to enter the Add page and add equipment to the power station

You can manually enter the serial number of the WIFI module, or you can click "Scan" to use your mobile phone to scan the WIFI module Barcodes are added. The serial number of the WIFI module is generally located on the box of the WIFI module, if the box has been lost, you are alsoThe code can be found in the WIFI module itself.

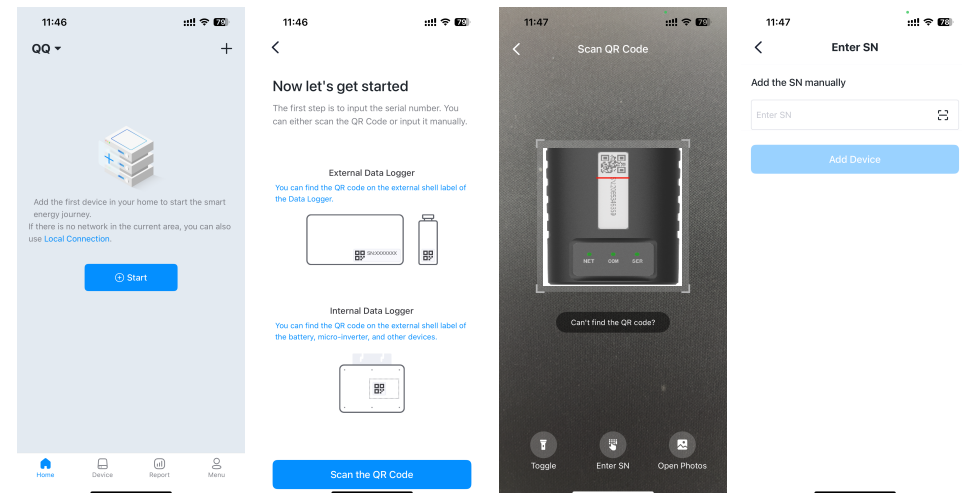

Step 2:

Make sure your phone is connected to your home Wi-Fi network, and tap Enter the connection password for that network. After entering and confirming that the information is correct, click the "Set Up" button.

Please be patient and wait for the configuration to complete automatically.

If the configuration is successful, click "Confirm", and the logger will remain in the "Offline" state.

Generally, within 5 minutes, the equipment can communicate normally and start collecting data from the photovoltaic system.

The "●" on the right side of the collector The color changes from gray to green, so please be patient.

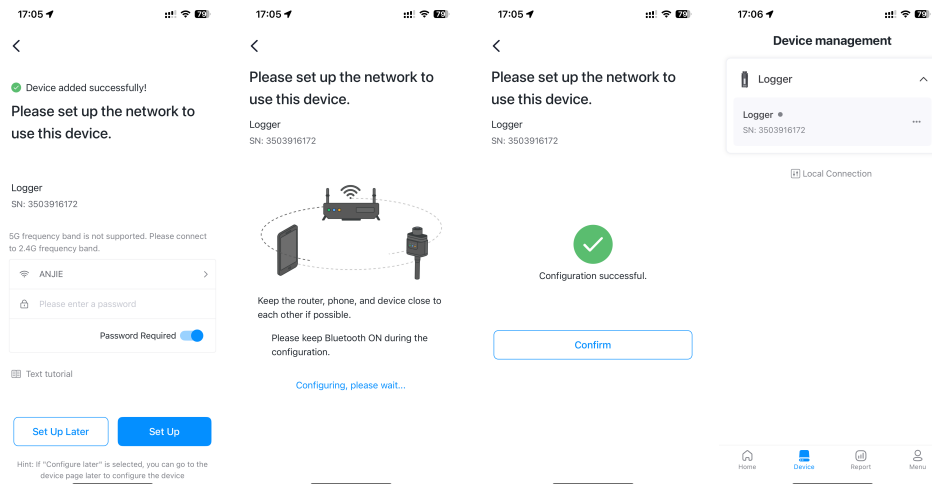

6.4 Mode Setting

Default setting for equipment tooling mode: Self-Consumed.

Customers can also modify the tooling mode to Time-Priority Mode and Battery-Priority Mode and Power Dispatch Mode according to actual needs.

To modify the working mode, please go to the "Device" page, select "..." on the right side of the "Inverter". Click "Remote Control" and then enter the "Batch Command" page of the device.

Select the EMS Settings command name and Set Working Mode.

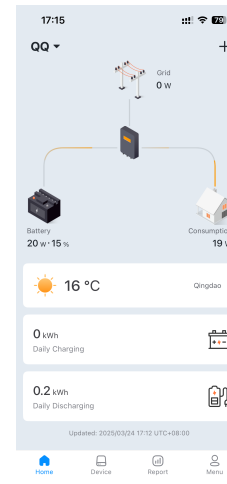
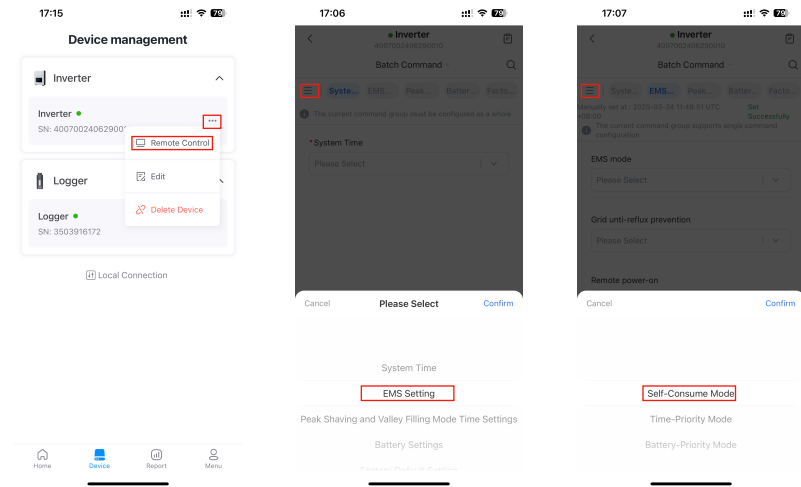

(a)

Click on the home page to display the configured APP interface (a)

Inverter LED light interface after successful configuration (b) SYSTEM and WIFI are shown in green The status of the other lights shows the corresponding color according to the configuration

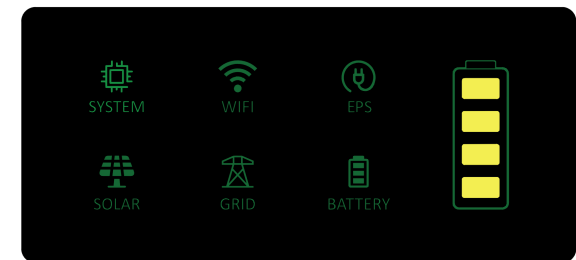

(b)

7. Shell Installation

7.1: Mount the battery side covers at both sides of the battery pack after finishing wiring and debugging.

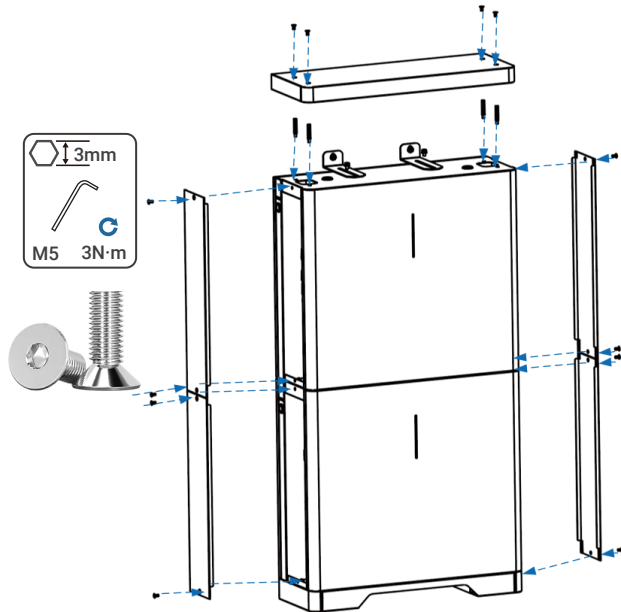

7.2: Mount the front trim cover on the inverter support leg after finishing wiring and debugging.

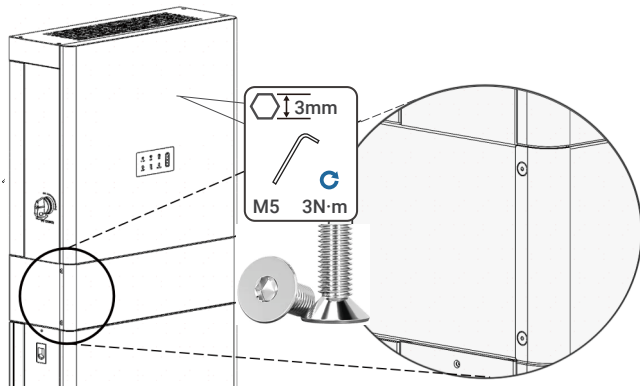

8. Power-off maintenance and common troubleshooting

8.1 Power-off maintenance

Power off and repair equipment in the recommended order.

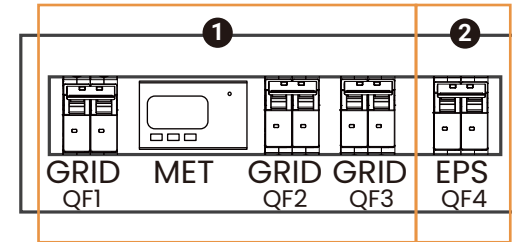

(Distribution box: Diagram QF1-4 corresponds to the electrical connection diagram on page 1)

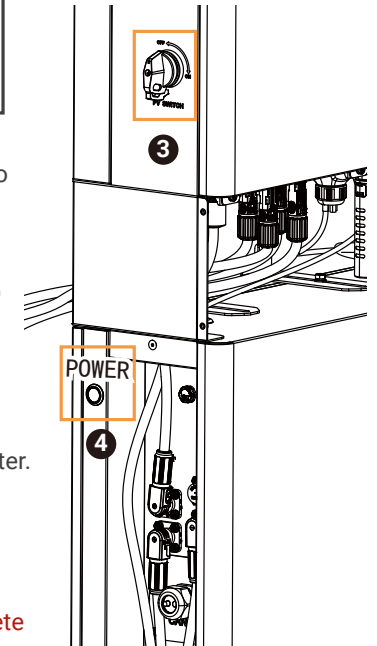

Step 1: Disconnect the EPS AC circuit breaker (2) inside the distribution box.

Step 2: Disconnect the GRID AC circuit breaker QF2 (1) inside the distribution box.

Step 3: Disconnect the PV switch (3) of the inverter.

Step 4: Press and hold the power button (4) for more than 3 seconds.

Note: Failure to disconnect (4) will result in complete battery drain and permanent battery damage!!!

Step 5: Use a screwdriver to turn the unlocking buckle of the GRID port and EPS port, remove the two power harnesses, and plug them together.

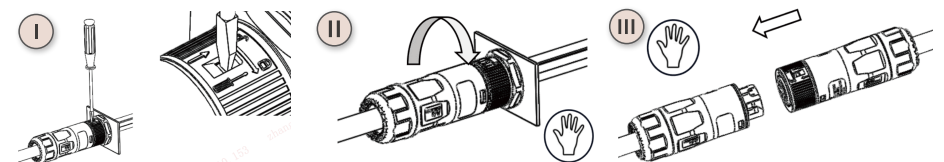



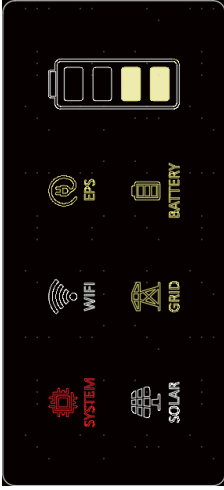
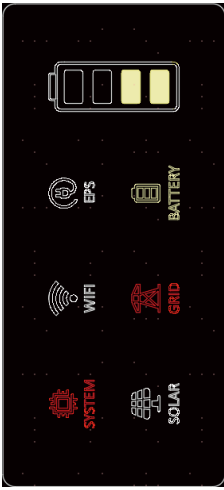
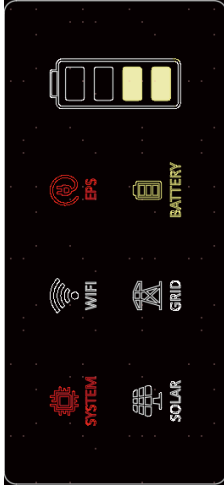

Step 6: Close the GRID AC circuit breaker QF2 (1) inside the distribution box.

Step 7: Close the EPS AC circuit breaker (2) inside the distribution box.

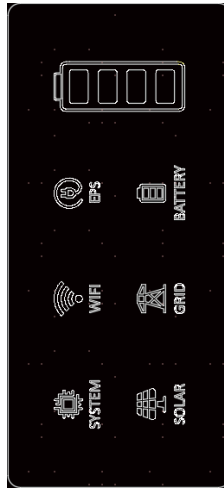
8.2 Common troubleshooting

No.	Indicator light status	problem	Solution
1		Smart meter communication failure	<ol style="list-style-type: none"> 1. Check if the meter interface 21 (485A) /22 (485B) is connected incorrectly; 2. Confirm the communication address and baud rate of the electricity meter according to the single page instruction manual; 3. Check if the inverter interface MET /485 is misconnected or loose.
2		Not connected to the grid	<ol style="list-style-type: none"> 1. Use a multimeter to measure the voltage of the GRID port circuit breaker.
3		EPS port voltage abnormality	<ol style="list-style-type: none"> 1. Use a multimeter to measure whether the EPS port circuit breaker has voltage. If electricity is confirmed, check if the EPS and GRID port connectors are connected incorrectly.

No.	Indicator light status	problem	Solution
4		The battery and PV are not connected	<ol style="list-style-type: none"> 1. Use a multimeter to measure whether there is voltage on the PV and whether the positive and negative connections are reversed; 2. Use a multimeter to measure whether there is voltage at the output ports P+and P - of the PACK; 3. Check if the power wire from the inverter to the PACK is poorly crimped, If so, replace the power wire.
5		Communication failure with inverter	<ol style="list-style-type: none"> 1. Re plug and unplug the CAN/485 communication cable from the inverter to the PACK; 2. Replace the CAN/485 communication cable between the inverter and the PACK.
6		Under voltage of battery cell or module	<ol style="list-style-type: none"> 1. Connect the PACK and inverter to power on normally, set the inverter to backup mode, and turn off all PACKs. set the undervoltage PACK dial to 0, press and hold the switch > 10s to forcefully start this PACK, and release the button after the purple light flashes. Use the inverter to charge to SOC 100%, then shut down and restore the dialing value before restarting.

No.	Indicator light status	problem	Solution
7		Excessive voltage difference between battery cells	1. Connect the PACK and inverter to power on normally, set the inverter to backup mode, and turn off all PACKs. set the undervoltage PACK dial to 0, press and hold the switch > 10s to forcefully start this PACK, and release the button after the purple light flashes. Use the inverter to charge to SOC 100%, then shut down and restore the dialing value before restarting.
8		PACK not powered on	1. Re plug and unplug the power harness between PACKs; 2. Check if the power harness is poorly crimped; if so, replace the power harness.